

### 1613-HVO Healthcare Vanity Sink (Integrated Overflow Model)

I.D.: 16 3/8" x 13" (416 mm x 330 mm)	 <b>ADA</b> Compliant
Depth: 5"* (127 mm)	
*Depth does not include counter top thickness	



The Gemstone 1613-HVO Vanity, specifically designed for Healthcare, is the culmination of design and function inspired by architects and designers who love the 1613-VO but need an offset drain to help prevent splashback. With the revelation in

2011 that *Pseudomonas aeruginosa* can live in the drains of sinks and can potentially be introduced into a patient room via splashback from a faucet hitting the drain, the 1613-HVO has an offset drain to prevent the potential problem. The depth of the bowl allows for easy ADA applications all the way to 17" depths, something most bowls can not do. The 1613-HVO has a smooth overflow tube which maximizes infection control in hospital applications in a bowl requiring an overflow.

Gemstone Sinks are compatible and warranted when used with all major solid surface sheet brands (acrylic and polyester) with the same sheet warranties.



Gemstone supports conservation and green building practices. Gemstone Packages all products in 100% recyclable packaging using boxes made primarily of recycled paper.



Gemstone sinks are proudly made in the USA and certified by:

**Home Innovation Lab** (NAHB): HUD UM Bulletin No. 73a & (B45.5/IAPMO Z124 Z124.6)

**UL** in the US and Canada: HUD UM Bulletin No. 73a & (B45.5/IAPMO Z124 Z124.6)



For router bit recommendations visit:  
[www.Gemstoness.com/Tech](http://www.Gemstoness.com/Tech)

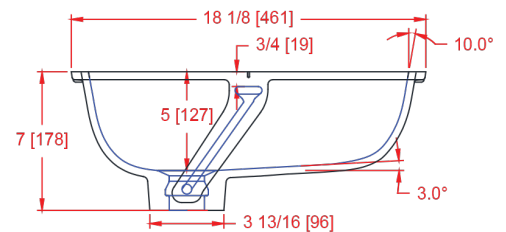
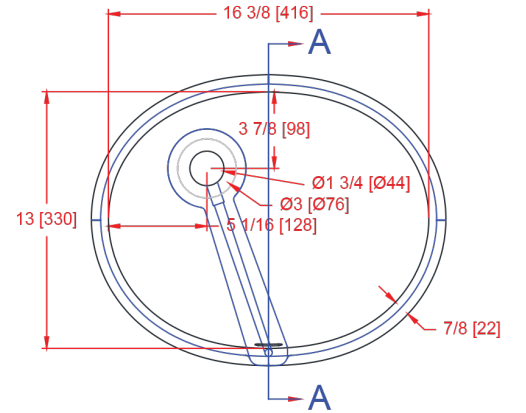

Front View

